

“PRECISION INJECTION MOLDING: MINI-SHUT™ NOZZLE TIP

THEORY VS. REALITY

Control of the Melting process depends on a number of factors including the proper screw and NRV design, and setting variables such as back pressure, barrel temperatures, screw speed and melt decompression. If we could eliminate the need for *Melt Decompression* which is used to eliminate drooling and stringing, the process becomes more stable part weight distribution is improved and many surface imperfections become obsolete!

INTRODUCING THE MINI-SHUT™ NOZZLE TIP

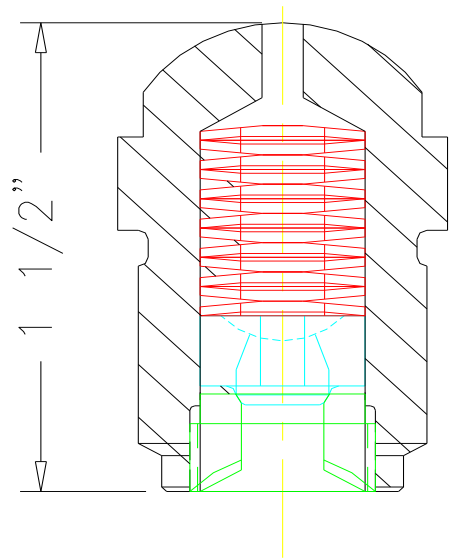
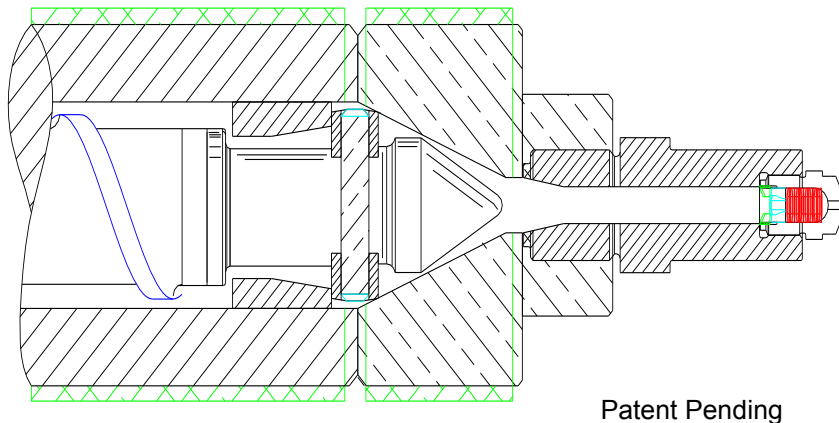

MINI-SHUT™ FEATURES

1. Easy to Install and Remove
2. Inexpensive
3. Fits on Virtually All Nozzle Bodies
4. Designs for All Machine Sizes-Applications
5. Operate the Clamp and Screw Simultaneously
6. On the Shelf Stock Item
7. Low Pressure Drop Low Shear
8. Operating Temperatures of + 750 degrees Fahrenheit
9. Easy to Clean with Normal Purging Techniques

MINI-SHUT™ BENEFITS

1. Eliminate Melt-Decompression
2. Eliminate Drooling
3. Eliminate Stringing
4. Improved Part Wt. Consistency

Md Plastics, Incorporated 
1361 Wardingley Ave., Columbiana, OH., 44408 USA
(330) 482-5100 fax (330) 482-5211 www.mdplastics.com